



## BME2 SERIES HYDRAULIC MOTOR

BME2 series motor adapt the advanced Geroler gear set designed with high speed distribution flow and high pressure, and have good stability in low speed , and can keep high volume efficiency. The unit can be supplied the individual variant in operating multifunction in accordance with requirement of applications.

### Characteristic features:

\* Advanced manufacturing devices for the Geroler gear set, which use low pressure of start-up, provide smooth and reliable operation and high efficiency.

\* The output shaft adapts in needle roller bearings that permit high axial and radial forces. The case can offers capacities of high pressure and high torque in the wide of applications.

\* Advanced design in high speed distribution flow, which can automatically compensate in operating with high volume efficiency and long life , provide smooth and reliable operation.

\* Lowest leakage rate, most accurate timing methods. Commutator rotates 6x faster than shaft speed. It make the distribution in a high precision reduces life-cycle cost, maintain high volume efficiencies and can run very smoothly at low speed, gear box not required.

### Main Specification

Type		BME2 65	BME2 80	BME2 100	BME2 125	BME2 160	BME2 200	BME2 230	BME2 250	BME2 295	BME2 315	BME2 375
Geometric displacement (cm <sup>3</sup> /rev.)		66.8	81.3	101.6	127	157.2	193.6	226	257	287.8	314.5	370
Max. speed (rpm)	cont.	667	543	439	350	283	229	247	216	196	178	152
	int.	842	689	553	441	355	289	328	287	254	235	199
Max. torque (N·m)	cont.	126	157	191	245	307	382	378	381	393	448	439
	int.	176	215	268	335	422	520	528	543	547	587	613
Max. output (kW)	cont.	8.3	8.8	7.9	8.9	8.9	9	9.9	9.3	8.7	8	7.6
	int.	13.9	14.4	13.5	14.1	15.6	15.7	17.9	16.5	15.6	14.3	14
Max. pressure drop (MPa)	cont.	14	14	14	14	14	14	12	11	10	10	9
	int.	19	19	19	19	19	19	165	15.5	14.5	13.5	12.5
	peak	20	20	20	20	20	20	18	18	17	16	16
Max. flow (L/min)	cont.	45	45	45	45	45	45	57	57	57	57	57
	int.	57	57	57	57	57	57	75	75	75	75	75

\* Continuous pressure:Max. value of operating motor continuously.

\* Intermittent pressure:Max. value of operating motor in 6 seconds per minute.

\* Peak pressure:Max. value of operating motor in 0.6 second per minute.

Performance Data

BME2 65 [66.8 cm<sup>3</sup>/rev.]

Pressure (MPa) Max.cont. Max.int.

	3.5	7	10.5	14	19		
Flow (L/min)	2	26 <b>22</b>	54 <b>16</b>	83 <b>4</b>			
	5	27 <b>69</b>	56 <b>62</b>	87 <b>53</b>	118 <b>42</b>		
	10	29 <b>145</b>	60 <b>141</b>	91 <b>132</b>	123 <b>122</b>	171 <b>95</b>	
	15	30 <b>221</b>	62 <b>216</b>	94 <b>207</b>	126 <b>196</b>	176 <b>149</b>	
	20	28 <b>295</b>	58 <b>290</b>	91 <b>279</b>	122 <b>261</b>	174 <b>232</b>	
	25	24 <b>368</b>	55 <b>365</b>	90 <b>352</b>	121 <b>341</b>	172 <b>312</b>	
	34	22 <b>501</b>	54 <b>493</b>	89 <b>478</b>	119 <b>457</b>	171 <b>423</b>	
	Max.cont.	45	20 <b>667</b>	52 <b>660</b>	85 <b>642</b>	115 <b>621</b>	168 <b>587</b>
	Max.int.	57	15 <b>842</b>	46 <b>835</b>	80 <b>814</b>	112 <b>789</b>	163 <b>735</b>

BME2 80 [81.3 cm<sup>3</sup>/rev.]

Pressure (MPa) Max.cont. Max.int.

	3.5	7	10.5	14	19		
Flow (L/min)	2	33 <b>18</b>	70 <b>14</b>	106 <b>4</b>			
	5	35 <b>55</b>	72 <b>51</b>	111 <b>44</b>	150 <b>25</b>		
	10	36 <b>121</b>	75 <b>118</b>	114 <b>113</b>	155 <b>107</b>	215 <b>88</b>	
	15	37 <b>181</b>	77 <b>178</b>	116 <b>171</b>	157 <b>162</b>	215 <b>148</b>	
	20	35 <b>242</b>	74 <b>238</b>	112 <b>231</b>	151 <b>223</b>	206 <b>205</b>	
	25	35 <b>303</b>	71 <b>298</b>	108 <b>289</b>	148 <b>275</b>	202 <b>261</b>	
	34	31 <b>411</b>	69 <b>407</b>	105 <b>396</b>	145 <b>382</b>	198 <b>373</b>	
	Max.cont.	45	23 <b>543</b>	62 <b>537</b>	100 <b>521</b>	139 <b>513</b>	12 <b>501</b>
	Max.int.	57	18 <b>689</b>	55 <b>681</b>	98 <b>665</b>	134 <b>649</b>	186 <b>618</b>

BME2 100 [101.6 cm<sup>3</sup>/rev.]

Pressure (MPa) Max.cont. Max.int.

	3.5	7	10.5	14	19		
Flow (L/min)	2	40 <b>15</b>	82 <b>11</b>	126 <b>4</b>			
	5	41 <b>44</b>	83 <b>36</b>	150 <b>28</b>	206 <b>12</b>		
	10	42 <b>97</b>	91 <b>95</b>	138 <b>94</b>	177 <b>81</b>	230 <b>54</b>	
	15	42 <b>147</b>	91 <b>144</b>	138 <b>137</b>	185 <b>124</b>	257 <b>93</b>	
	20	38 <b>195</b>	88 <b>192</b>	136 <b>182</b>	180 <b>169</b>	244 <b>138</b>	
	25	39 <b>244</b>	89 <b>241</b>	142 <b>230</b>	191 <b>221</b>	268 <b>194</b>	
	34	31 <b>331</b>	79 <b>328</b>	131 <b>323</b>	179 <b>308</b>	250 <b>273</b>	
	Max.cont.	45	21 <b>439</b>	70 <b>436</b>	119 <b>433</b>	168 <b>419</b>	241 <b>383</b>
	Max.int.	57	10 <b>553</b>	60 <b>545</b>	109 <b>534</b>	158 <b>527</b>	232 <b>491</b>

BME2 125 [127 cm<sup>3</sup>/rev.]

Pressure (MPa) Max.cont. Max.int.

	3.5	7	10.5	14	19		
Flow (L/min)	2	52 <b>12</b>	150 <b>9</b>	158 <b>3</b>			
	5	55 <b>35</b>	112 <b>31</b>	170 <b>22</b>	221 <b>15</b>	290 <b>10</b>	
	10	57 <b>78</b>	117 <b>75</b>	180 <b>69</b>	242 <b>63</b>	335 <b>46</b>	
	15	56 <b>116</b>	118 <b>113</b>	180 <b>109</b>	245 <b>99</b>	331 <b>76</b>	
	20	55 <b>155</b>	117 <b>153</b>	178 <b>147</b>	242 <b>136</b>	331 <b>110</b>	
	25	52 <b>593</b>	111 <b>188</b>	177 <b>182</b>	238 <b>172</b>	325 <b>151</b>	
	34	43 <b>264</b>	105 <b>262</b>	169 <b>254</b>	231 <b>244</b>	326 <b>220</b>	
	Max.cont.	45	38 <b>350</b>	95 <b>348</b>	159 <b>346</b>	219 <b>331</b>	314 <b>301</b>
	Max.int.	57	21 <b>441</b>	176 <b>439</b>	141 <b>431</b>	280 <b>417</b>	302 <b>384</b>

Torque (N·m) 158  
Speed (rpm) 527

□ cont.  
■ int.

### Performance Data

BME2 160 [157.2 cm<sup>3</sup>/rev.]

		Pressure (MPa)					
		3.5	7	10.5	14	19	
Flow (L/min)	2	64 <b>10</b>	132 <b>8</b>	199 <b>2</b>			
	5	68 <b>28</b>	138 <b>26</b>	208 <b>19</b>	281 <b>10</b>		
	10	71 <b>62</b>	147 <b>60</b>	221 <b>56</b>	303 <b>53</b>	419 <b>38</b>	
	15	72 <b>93</b>	148 <b>91</b>	225 <b>87</b>	307 <b>79</b>	426 <b>61</b>	
	20	71 <b>126</b>	148 <b>123</b>	223 <b>118</b>	305 <b>110</b>	422 <b>95</b>	
	25	62 <b>157</b>	140 <b>155</b>	218 <b>152</b>	296 <b>141</b>	415 <b>129</b>	
	34	56 <b>214</b>	134 <b>211</b>	211 <b>206</b>	287 <b>197</b>	408 <b>181</b>	
	Max.cont.	45	47 <b>283</b>	127 <b>281</b>	205 <b>275</b>	281 <b>266</b>	391 <b>241</b>
	Max.int.	57	36 <b>355</b>	97 <b>352</b>	182 <b>346</b>	260 <b>336</b>	370 <b>311</b>

BME2 200 [193.6 cm<sup>3</sup>/rev.]

		Pressure (MPa)					
		3.5	7	10.5	14	19	
Flow (L/min)	2	80 <b>9</b>	163 <b>7</b>	245 <b>3</b>			
	5	88 <b>23</b>	178 <b>21</b>	266 <b>18</b>	352 <b>12</b>		
	10	89 <b>49</b>	181 <b>48</b>	275 <b>43</b>	378 <b>39</b>	517 <b>27</b>	
	15	91 <b>76</b>	188 <b>73</b>	280 <b>68</b>	382 <b>63</b>	520 <b>44</b>	
	20	89 <b>101</b>	182 <b>98</b>	275 <b>95</b>	374 <b>86</b>	517 <b>69</b>	
	25	78 <b>127</b>	170 <b>125</b>	271 <b>121</b>	376 <b>113</b>	518 <b>101</b>	
	34	64 <b>173</b>	158 <b>171</b>	268 <b>165</b>	363 <b>156</b>	502 <b>143</b>	
	Max.cont.	45	51 <b>229</b>	157 <b>227</b>	252 <b>221</b>	351 <b>212</b>	494 <b>196</b>
	Max.int.	57	36 <b>289</b>	138 <b>286</b>	231 <b>279</b>	330 <b>271</b>	469 <b>256</b>

BME2 230 [226 cm<sup>3</sup>/rev.]

		Pressure (MPa)					
		3.5	7	10.5	12	16.5	
Flow (L/min)	2	97 <b>7</b>	191 <b>4</b>	280 <b>2</b>			
	5	101 <b>18</b>	199 <b>14</b>	301 <b>8</b>	348 <b>4</b>		
	10	103 <b>43</b>	214 <b>42</b>	325 <b>40</b>	378 <b>36</b>	527 <b>29</b>	
	15	104 <b>65</b>	215 <b>63</b>	327 <b>59</b>	375 <b>52</b>	528 <b>47</b>	
	20	101 <b>86</b>	210 <b>84</b>	321 <b>81</b>	371 <b>75</b>	524 <b>66</b>	
	25	95 <b>108</b>	201 <b>106</b>	316 <b>102</b>	364 <b>94</b>	511 <b>87</b>	
	34	82 <b>147</b>	188 <b>145</b>	308 <b>141</b>	358 <b>135</b>	501 <b>128</b>	
	45	55 <b>197</b>	158 <b>195</b>	276 <b>191</b>	329 <b>186</b>	485 <b>176</b>	
	Max.cont.	57	19 <b>247</b>	130 <b>244</b>	256 <b>240</b>	301 <b>230</b>	451 <b>221</b>
	Max.int.	75		65 <b>328</b>	183 <b>323</b>	250 <b>311</b>	401 <b>303</b>

BME2 250 [257 cm<sup>3</sup>/rev.]

		Pressure (MPa)					
		3.5	7	10.5	11	15.5	
Flow (L/min)	2	112 <b>6</b>	207 <b>3</b>	309 <b>1</b>			
	5	115 <b>18</b>	218 <b>14</b>	320 <b>8</b>	348 <b>4</b>		
	10	113 <b>39</b>	235 <b>38</b>	358 <b>35</b>	379 <b>31</b>	543 <b>23</b>	
	15	113 <b>58</b>	234 <b>56</b>	357 <b>53</b>	381 <b>45</b>	542 <b>3</b>	
	20	111 <b>77</b>	233 <b>75</b>	356 <b>72</b>	376 <b>65</b>	541 <b>48</b>	
	25	109 <b>97</b>	228 <b>95</b>	354 <b>89</b>	371 <b>81</b>	532 <b>69</b>	
	34	91 <b>131</b>	213 <b>128</b>	346 <b>123</b>	364 <b>116</b>	521 <b>103</b>	
	45	89 <b>174</b>	211 <b>172</b>	345 <b>165</b>	361 <b>157</b>	518 <b>135</b>	
	Max.cont.	57	73 <b>216</b>	208 <b>213</b>	339 <b>205</b>	342 <b>197</b>	487 <b>184</b>
	Max.int.	75		74 <b>287</b>	198 <b>284</b>	301 <b>278</b>	441 <b>267</b>

Torque (N·m) 250  
Speed (rpm) 311

□ cont.  
■ int.

### Performance Data

BME2 295[287.8 cm<sup>3</sup>/rev.]

Pressure (MPa)

Max.int.

3.5	7	11	14.5
-----	---	----	------

Flow (L/min)	5	121 <b>15</b>	243 <b>14</b>	368 <b>10</b>	509 <b>5</b>
	10	125 <b>33</b>	253 <b>31</b>	381 <b>27</b>	529 <b>20</b>
	15	129 <b>51</b>	261 <b>50</b>	393 <b>47</b>	547 <b>41</b>
	20	127 <b>68</b>	259 <b>67</b>	390 <b>63</b>	545 <b>55</b>
	25	126 <b>86</b>	255 <b>84</b>	386 <b>80</b>	539 <b>69</b>
	34	123 <b>116</b>	248 <b>114</b>	380 <b>110</b>	531 <b>98</b>
	45	115 <b>154</b>	234 <b>153</b>	368 <b>148</b>	522 <b>136</b>
	Max.cont.	108 <b>196</b>	227 <b>194</b>	359 <b>187</b>	514 <b>176</b>
	Max.int.	75	211 <b>254</b>	349 <b>246</b>	506 <b>231</b>

BME2 315[314.5 cm<sup>3</sup>/rev.]

Pressure (MPa)

Max.int.

3.5	7	11	13.5
-----	---	----	------

Flow (L/min)	5	136 <b>11</b>	281 <b>8</b>	427 <b>3</b>	
	10	139 <b>30</b>	287 <b>29</b>	438 <b>26</b>	574 <b>20</b>
	15	141 <b>47</b>	295 <b>46</b>	448 <b>43</b>	587 <b>40</b>
	20	138 <b>62</b>	287 <b>61</b>	442 <b>58</b>	587 <b>53</b>
	25	131 <b>78</b>	280 <b>75</b>	431 <b>71</b>	567 <b>66</b>
	34	117 <b>106</b>	269 <b>104</b>	423 <b>98</b>	557 <b>91</b>
	45	114 <b>141</b>	253 <b>138</b>	397 <b>132</b>	535 <b>125</b>
	Max.cont.	86 <b>178</b>	219 <b>173</b>	383 <b>168</b>	505 <b>162</b>
	Max.int.	75	108 <b>235</b>	287 <b>231</b>	416 <b>219</b>

BME2 375[370 cm<sup>3</sup>/rev.]

Pressure (MPa)

Max.int.

3.5	7	9	12.5
-----	---	---	------

Flow (L/min)	5	151 <b>10</b>	315 <b>7</b>	412 <b>3</b>	
	10	155 <b>25</b>	324 <b>24</b>	427 <b>21</b>	606 <b>18</b>
	15	162 <b>40</b>	331 <b>39</b>	439 <b>37</b>	613 <b>32</b>
	20	158 <b>53</b>	326 <b>52</b>	434 <b>49</b>	602 <b>45</b>
	25	151 <b>67</b>	316 <b>65</b>	424 <b>62</b>	589 <b>58</b>
	34	141 <b>91</b>	309 <b>89</b>	417 <b>85</b>	580 <b>80</b>
	45	138 <b>121</b>	300 <b>119</b>	408 <b>115</b>	572 <b>107</b>
	Max.cont.	118 <b>152</b>	281 <b>150</b>	393 <b>144</b>	550 <b>136</b>
	Max.int.	75	258 <b>199</b>	369 <b>191</b>	518 <b>183</b>

Torque (N·m) 506  
Speed (rpm) 231

□ cont.  
■ int.

**BME2 DIMENSIONS AND MOUNTING DATA**

**Wheel Mount**

Code: Port A、B  
WS 7/8-14 O-ring  
WD G1/2  
WM M22x1.5

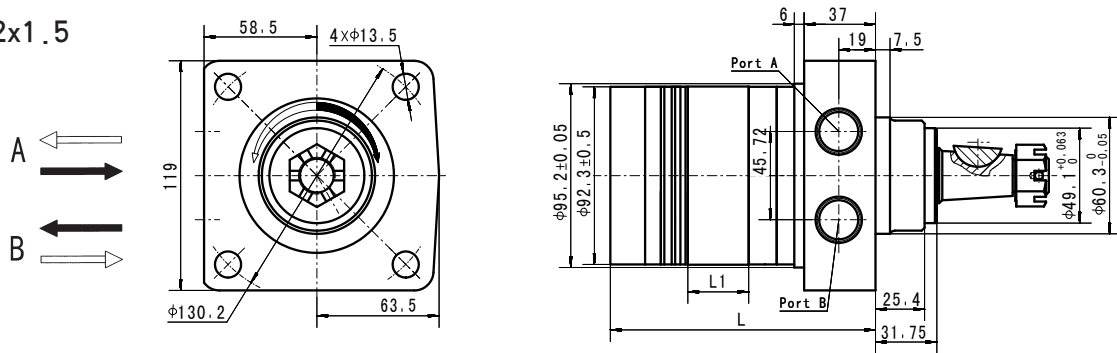

Displacement (cm <sup>3</sup> /rev.)	65	80	100	125	160	200	230	250	295	315	375
L1(mm)	13	16	20	25	30.5	38.1	44	50	56	62	74
L(mm)	119	122	126	131	136.5	144	150	156	162	168	180
Weight(kg)	7.4	7.5	7.8	8	8.3	8.7	9.2	9.6	10	10.3	10.8

Code:HM Manifold  
A、B Port  $\phi 12.7$

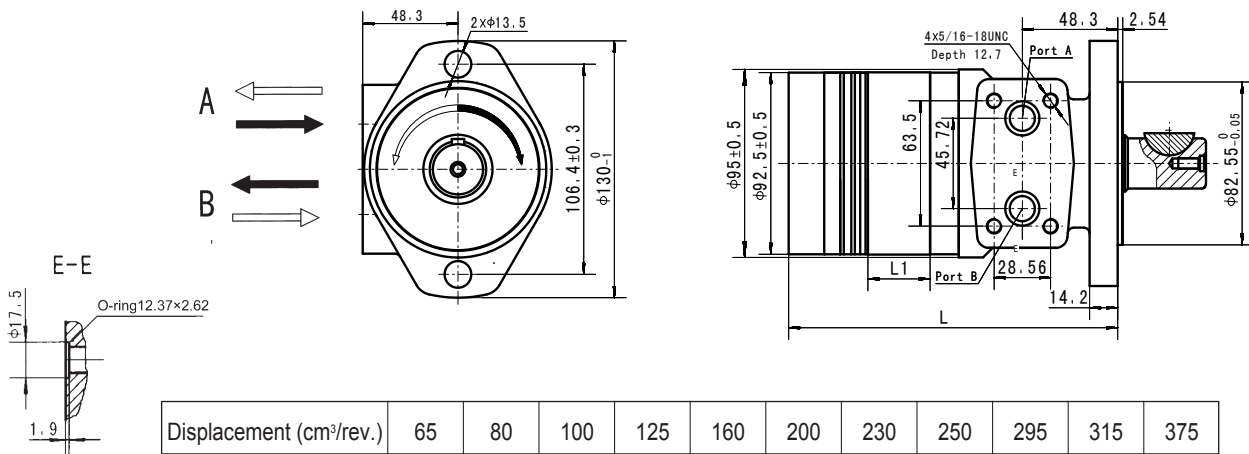

Displacement (cm <sup>3</sup> /rev.)	65	80	100	125	160	200	230	250	295	315	375
L1(mm)	13	16	20	25	30.5	38.1	44	50	56	62	74
L(mm)	149	152	156	161	166.5	174	180	186	192	198	210
Weight(kg)	6.4	6.5	6.8	7	7.3	7.7	8.2	8.6	9	9.3	9.8

**BME2 DIMENSIONS AND MOUNTING DATA**

Code: Port A、B  
HS 7/8-14UNF  
HP 1/2-14NPTF  
HD G1/2  
HG M22x1.5

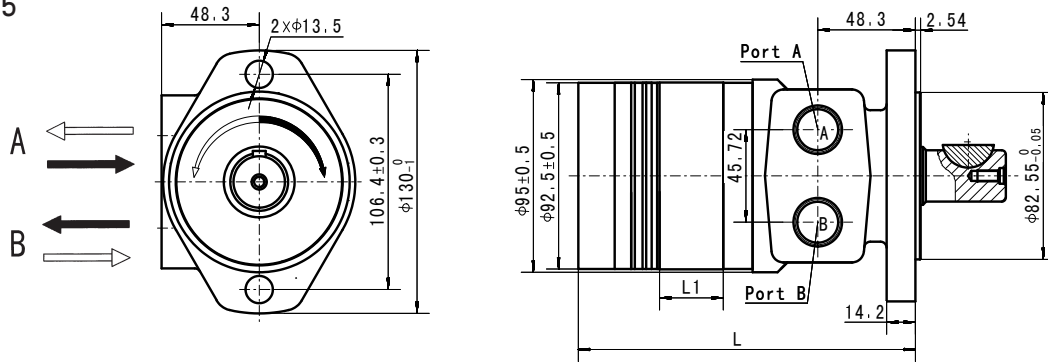

Displacement (cm <sup>3</sup> /rev.)	65	80	100	125	160	200	230	250	295	315	375
L1(mm)	13	16	20	25	30.5	38.1	44	50	56	62	74
L(mm)	149	152	156	161	166.5	174	180	186	192	198	210
Weight(kg)	6.4	6.5	6.8	7	7.3	7.7	8.2	8.6	9	9.3	9.8

Code: Port A、B  
H4S 7/8-14UNF  
H4P 1/2-14NPTF  
H4D G1/2  
H4G M22x1.5

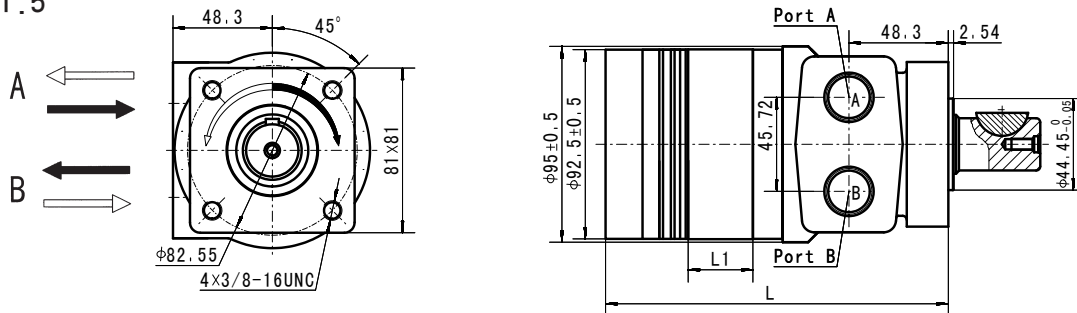

Displacement (cm <sup>3</sup> /rev.)	65	80	100	125	160	200	230	250	295	315	375
L1(mm)	13	16	20	25	30.5	38.1	44	50	56	62	74
L(mm)	149	152	156	161	166.5	174	180	186	192	198	210
Weight(kg)	6.4	6.5	6.8	7	7.3	7.7	8.2	8.6	9	9.3	9.8

**BME2 SHAFT EXTENSIONS DIMENSIONS DATA**

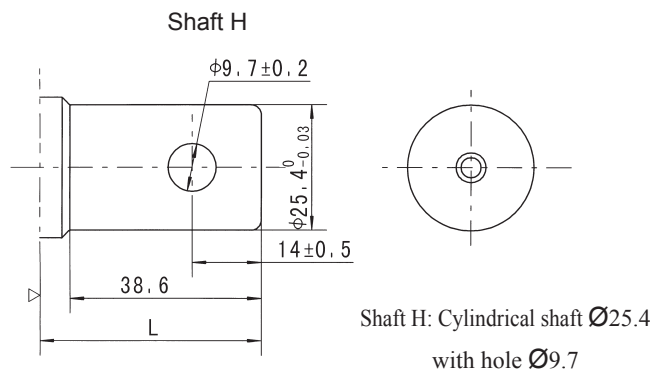
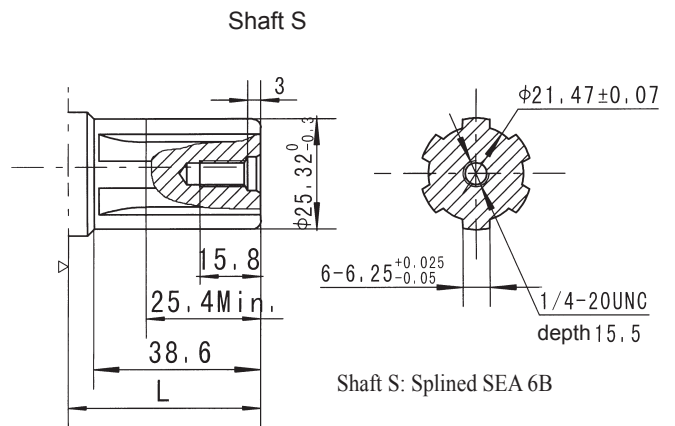
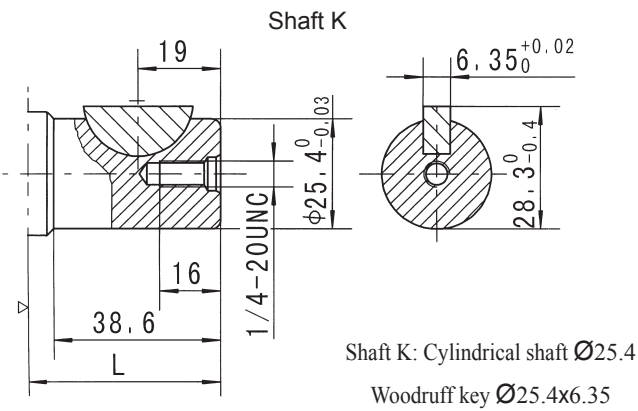
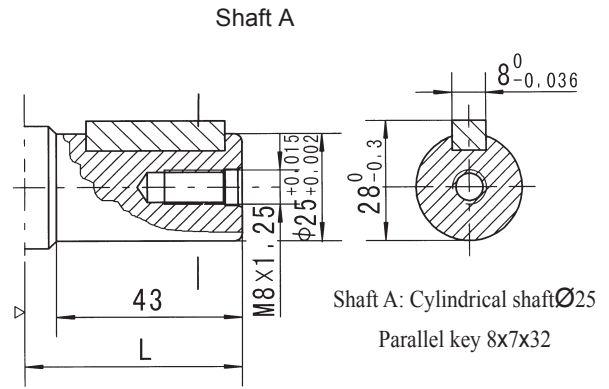
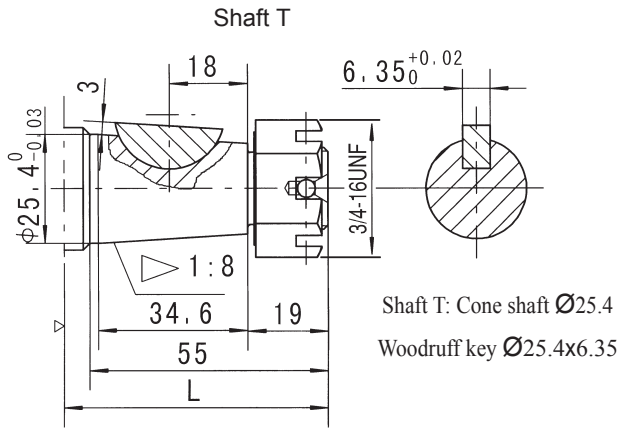

Dimension L

Shaft Mounting	T	A	K	S	H
WS	90.2	78.2	73.9	73.9	73.9
HS/HP					
H4S/H4P	61	49	44.7	44.7	44.7
HM					

▷ Motor Mounting Surface

Permissible Shaft Loads

BME2 for Wheel Mounting

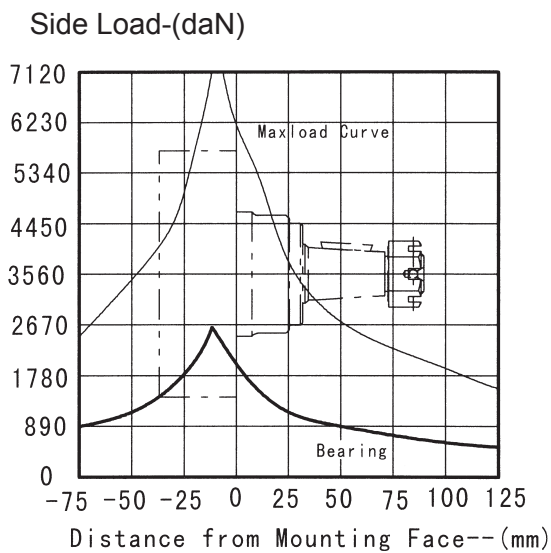

BME2 for Other Mounting

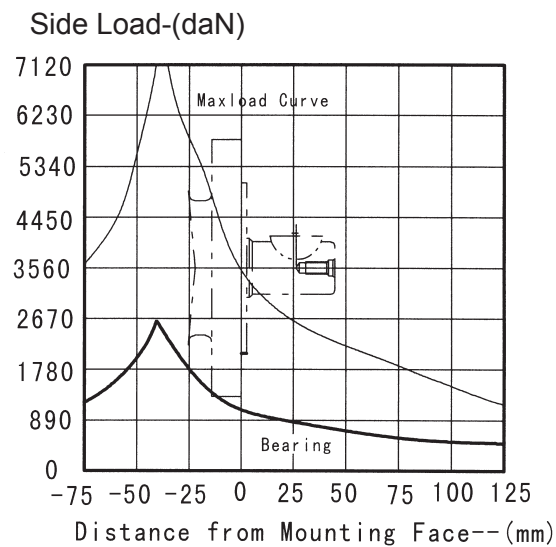

The bearing curve represents allowable bearing loads for an  $L_{10}$  bearing life at  $3 \times 10^6$  revolutions,  
The maximum load curve is defined by bearing static load capacity, This curve should not be exceeded at any time including shock loads.



Order Information

1  2  3  4  5  6  7

BME2

Pos.1	2	3	4	5	6	7
Code	Disp.	Flange,Pilot,Ports	Output Shaft	Rotation Direction	Paint	Unusually Function
WS		4-Ø13.5 Wheel - flange,Pilot Ø60.3×7 Port 7/8-14 O-ring	T Cone-Shaft Ø25.4,Woodruff key Ø25.4×6.35 A Cylindrical Shaft Ø25, Parallel key 8×7×32 K Cylindrical Shaft Ø25.4, Woodruff key Ø25.4×6.35 S Shaft Ø25.4, Splined key SAE 6B H Cylindrical Shaft Ø25.4,Pin Hole Ø9.7	Omit Standard R Opposite	00 No paint Omit Blue B Black S Silver grey	
WD		4-Ø13.5 Wheel -flange,Pilot Ø60.3×7 Port G1/2				
WM		4-Ø13.5 Wheel -flange,Pilot Ø60.3×7 Port M22×1.5				
HM	65	2-Ø13.5 Rhomb-flange,Pilot Ø82.5×2.54				
HS	80	Port 1/2" Manifold mount 4×5/8-18				
Omit	100	2-Ø13.5 Rhomb-flange,Pilot Ø82.5×2.54				
	125	Port 7/8-14 O-ring				
	160	2-Ø13.5 Rhomb-flange,Pilot Ø82.5×2.54				
	200	Port 1/2-14 NPFT Pipe				
	230	2-Ø13.5 Rhomb-flange,Pilot Ø82.5×2.54				
	250	Port G1/2				
	295	2-Ø13.5 Rhomb-flange,Pilot Ø82.5×2.54				
	315	Port M22×1.5				
	375	4-3/8-16 Square- flange,Pilot Ø44.4×2.54 Port 7/8-14 O-ring				
		4-3/8-16 Square- flange,Pilot Ø44.4×2.54 Port 1/2-14 NPFT Pipe				
		4-3/8-16 Square- flange,Pilot Ø44.4×2.54 Port G1/2				
		4-3/8-16 Square- flange,Pilot Ø44.4×2.54 Port M22×1.5				

Note:When the table is used, please fill the code of left rows in the table and give us, which the code information is consists of construction, displacement, mounting flange, output shaft and ports. If the specification is not in the table or you have specific requirements, please contract us.

# 专业做液压-专注做精品

PROFESSIONAL ON HYDRAULIC- FOCUS ON HIGH QUALITY



## 石家庄寒九科技有限公司

地址：中国河北石家庄友谊北大街398号

电话：+86 ( 311 ) 68123061

传真：+86 ( 10 ) - 80115555-568844

邮编：050000

网址：www.hjhydraulic.com

邮箱：manager@sjzhjism.com

## SHIJIAZHUANG HANJIU TECHNOLOGY CO.,LTD.

Add: No. 398 Youyi Street, Shijiazhuang, Hebei, China

Tel: +86 (311) 68123061

Fax: +86 (10) - 80115555-568844

Post code: 050000

Web: www.hjhydraulic.com

Email: manager@sjzhjism.com